

JVC

VIDEO CASSETTE RECORDER

HR-A437E HR-A237E
HR-A433E HR-A233E
HR-A430E HR-A230E

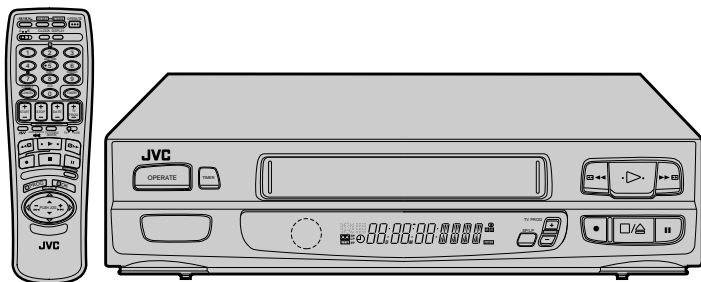

Unless otherwise indicated, the recorder illustrations appearing in this instruction manual are of the HR-A433E.

SHOWVIEW



INSTRUCTIONS

ENGLISH

CONTENTS

SAFETY FIRST	2
Safety Precautions	2
INSTALLING YOUR NEW RECORDER	3
Basic Connections	3
Tune The TV To Your Video Recorder	3
Connecting/Using A Decoder [A233E, A433E only]	4
Connecting/Using A Satellite Tuner	5
INITIAL SETTINGS	6
Tuner Set	6
Clock Set	7
PLAYBACK	9
Basic Playback	9
Playback Features	10
RECORDING	13
Basic Recording	13
Recording Features	14
TIMER RECORDING	15
Information On ShowView [except A230E, A430E]	15
Guide Prog. Number Set [except A230E, A430E]	15
ShowView Timer Recording [except A230E, A430E]	17
Regular Timer Programming	18
Check And Cancel Programmes	19
PDC/VPS Recording [A237E, A437E only]	19
EDITING	20
Edit To Or From Another Video Recorder	20
Edit From A Camcorder	21
USING THE CONFIRMATION DISPLAY	22
Storing Channels Manually	22
Delete A Channel	22
Change Station Channel Position	22
Set Stations	23
Fine-Tuning Channels Already Stored	23
TV STATION AND ID LIST	24
TROUBLESHOOTING	25
QUESTIONS AND ANSWERS	27
INDEX	28
SPECIFICATIONS	32



Safety Precautions

The rating plate and the safety caution are on the rear of the unit.

WARNING: DANGEROUS VOLTAGE INSIDE

WARNING: TO PREVENT FIRE OR SHOCK HAZARD, DO NOT EXPOSE THIS UNIT TO RAIN OR MOISTURE.

CAUTION

- When you are not using the recorder for a long period of time, it is recommended that you disconnect the power cord from the mains outlet.
- Dangerous voltage inside. Refer internal servicing to qualified service personnel. To prevent electric shock or fire hazard, remove the power cord from the mains outlet prior to connecting or disconnecting any signal lead or aerial.

IMPORTANT

- Please read the various precautions on this page before installing or operating the recorder.
- It should be noted that it may be unlawful to re-record pre-recorded tapes, records, or discs without the consent of the owner of copyright in the sound or video recording, broadcast or cable programme and in any literary, dramatic, musical, or artistic work embodied therein.

WARNING

There are two different types of SECAM colour systems: SECAM-L, used in FRANCE (also called SECAM-West), and SECAM-B, used in Eastern European countries (also called SECAM-East).

1. This recorder can also receive SECAM-B colour television signals for recording and playback.
2. Recordings made of SECAM-B television signals produce monochrome pictures if played back on a video recorder of SECAM-L standard, or do not produce normal colour pictures if played back on a PAL video recorder with SECAM-B system incorporated (even if the TV set is SECAM-compatible).
3. SECAM-L prerecorded cassettes or recordings made with a SECAM-L video recorder produce monochrome pictures when played back with this recorder.
4. This recorder cannot be used for the SECAM-L standard. Use a SECAM-L recorder to record SECAM-L signals.

The OPERATE button does not completely shut off mains power from the unit, but switches operating current on and off.

To A430E/A433E/A437E Owners:

Video tapes recorded with this video recorder in the LP (Long Play) mode cannot be played back on a single-speed video recorder.

Failure to heed the following precautions may result in damage to the recorder, remote control or video cassette.

1. **DO NOT** place the recorder . . .

- ... in an environment prone to extreme temperatures or humidity.
- ... in direct sunlight.
- ... in a dusty environment.
- ... in an environment where strong magnetic fields are generated.
- ... on a surface that is unstable or subject to vibration.

2. **DO NOT** block the recorder's ventilation openings.

3. **DO NOT** place heavy objects on the recorder or remote control.

4. **DO NOT** place anything which might spill on top of the recorder or remote control.

5. **AVOID** violent shocks to the recorder during transport.

MOISTURE CONDENSATION

Moisture in the air will condense on the recorder when you move it from a cold place to a warm place, or under extremely humid conditions—just as water droplets form in the surface of a glass filled with cold liquid. Moisture condensation on the head drum will cause damage to the tape. In conditions where condensation may occur, keep the recorder turned on for a few hours to let the moisture dry.

ABOUT HEAD CLEANING

Accumulation of dirt and other particles on the video heads may cause the playback picture to become blurred or interrupted. Be sure to contact your nearest JVC dealer if such troubles occur.

For Italy:

"It is declared that this product, brand JVC, conforms to the Ministry Decree n. 548 of 28 Aug.'95 published in the Official Gazette of the Italian Republic n. 301 of 28 Dec.'95"



- Only cassettes marked "VHS" can be used with this videorecorder.
- HQ VHS is compatible with existing VHS equipment.
- ShowView is a trademark applied for by Gemstar Development Corporation. The ShowView system is manufactured under licence from Gemstar Development Corporation.



INSTALLING YOUR NEW RECORDER

3

Basic Connections

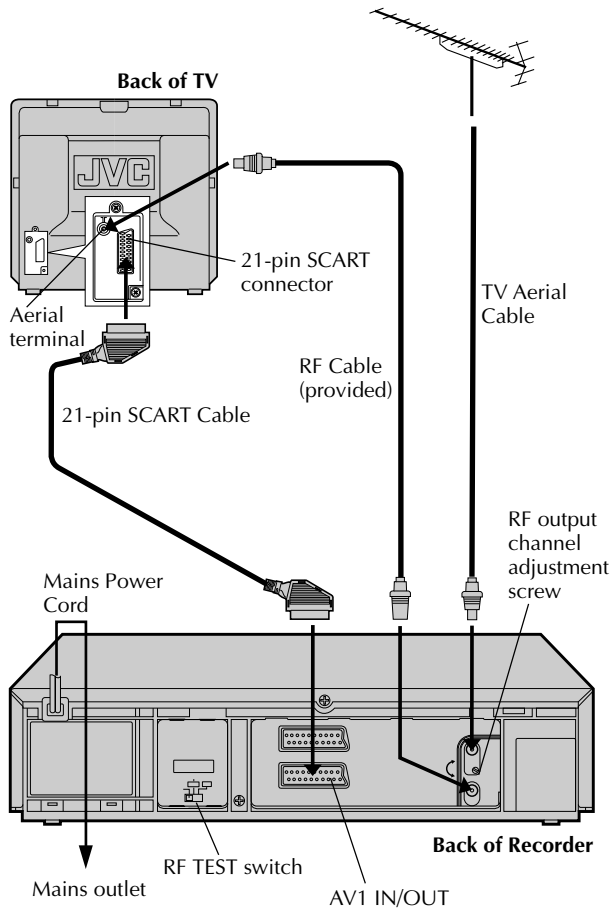

It's essential that your video recorder be properly connected. Follow these steps carefully. THESE STEPS MUST BE COMPLETED BEFORE ANY VIDEO OPERATION CAN BE PERFORMED.

- 1 CHECK CONTENTS**
Make sure the package contains all of the accessories listed in "Specifications" (☞ pg. 32).
- 2 SITUATE RECORDER**
Place the recorder on a stable, horizontal surface.
- 3 CONNECT RECORDER TO TV**
The connection method you use depends on the type of TV you have.
RF CONNECTION
 - To Connect To A TV With NO AV Input Terminals . . .
 - a- Disconnect the TV aerial cable from the TV.
 - b- Connect the TV aerial cable to the ANT. IN jack on the rear panel of the recorder.
 - c- Connect the provided RF cable between the RF OUT jack on the rear panel of the recorder and the TV's aerial terminal.

Before operating the recorder, make sure the TV's channel is set to the VIDEO channel.

AV CONNECTION
 - To Connect To A TV With AV Input Terminals . . .
 - a- Connect the aerial, recorder and TV as per "RF CONNECTION".
 - b- Connect an optional SCART cable between the AV1 IN/OUT socket on the rear panel of the recorder and the TV's 21-pin SCART connector.
 - c- Set the RF TEST switch to OFF.

Before operating the recorder, make sure the TV is set to the VIDEO (or AV) mode.
- 4 CONNECT RECORDER TO MAINS**
Plug the end of the mains power cord into a mains outlet.

Tune The TV To Your Video Recorder

The video recorder sends picture and sound signals via the RF connecting cable to your TV on UHF channel 36.

- 1 TURN ON THE RECORDER**
Press **OPERATE**.
- 2 SELECT OUTPUT MODE**
Set the **RF TEST** switch on the back of the recorder to **ON**.

CONTINUED ON NEXT PAGE.



4

INSTALLING YOUR NEW RECORDER (cont'd)

SET TV CHANNEL

3

Set your TV to the video channel (UHF channel 36). Two white bars appear on screen vertically.

- Tune the TV until the bars are as clear as they can be.
- Your TV should be set to the channel designated for use with a video recorder, or to a spare channel if there is not a specified video channel on your TV.

RESET OUTPUT MODE

4

Return the **RF TEST** switch to OFF.

NOTES:

- If CH36 is occupied by a local station, adjust the RF output channel adjustment screw to use another channel between CH32 and CH40 instead.
- If some interference noise is continually seen on the screen, consult your JVC dealer.

The AV2 IN/DECODER connector can be used as an input terminal for an external decoder (descrambler). Simply connect a decoder and you can enjoy the variety of programming that is available through scrambled channels.

Connecting/ Using A Decoder (A233E, A433E only)

SELECT INPUT MODE

1

Set the **AV2 SELECT** switch to "DECODER".

CONNECT DECODER

2

Connect your recorder's AV2 IN/DECODER connector to the decoder's Euroconnector using a 21-pin SCART cable.

SET TUNER

3

Follow the procedure starting on page 6.

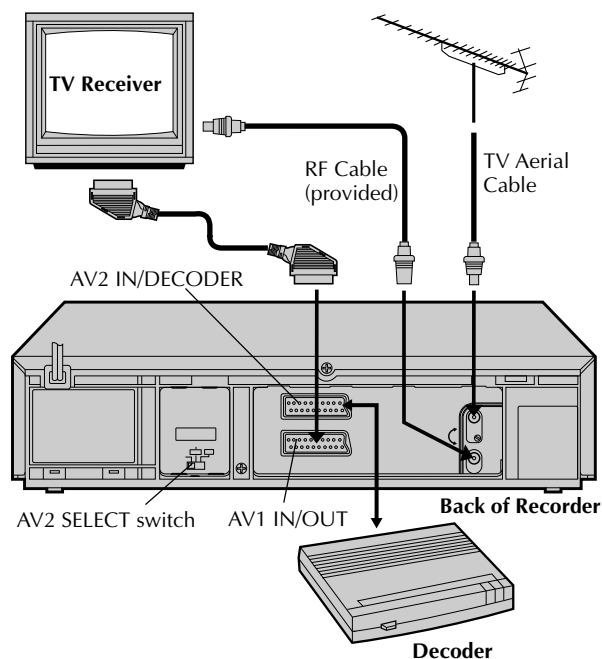

Connecting/ Using A Satellite Tuner

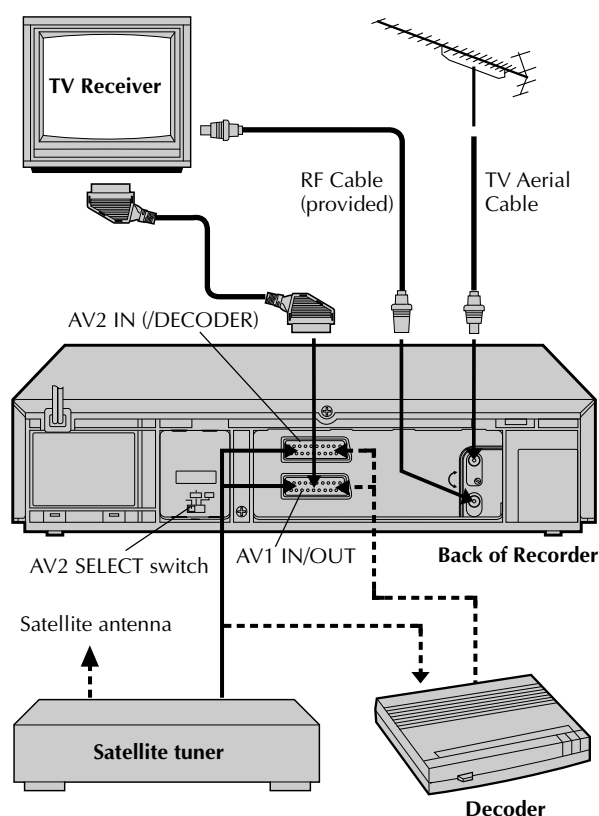

NOTE:

When connecting a satellite tuner together with a decoder . . .
 . . . first connect the satellite tuner's output connector to the decoder's input connector, then connect the decoder's output connector to the recorder's AV2 IN or AV1 IN/OUT connector (depending on the model of recorder you own).

The AV2 IN (/DECODER) or AV1 IN/OUT connector can be used as an input terminal for a satellite tuner. Simply connect a satellite tuner and you can enjoy the wide variety of satellite programming.

1 SELECT INPUT MODE (A233E, A433E only)

Set the AV2 SELECT switch to "AV2".

2 CONNECT SATELLITE TUNER

- If you own the A230E, A430E or A437E . . .
 . . . connect an optional 21-pin SCART cable between the satellite tuner's Euroconnector and your recorder's AV1 IN/OUT connector.
- If you own the A233E, A237E or A433E . . .
 . . . connect an optional 21-pin SCART cable between the satellite tuner's Euroconnector and your recorder's AV2 IN (/DECODER) connector.

3 PREPARE TO WATCH A SATELLITE PROGRAMME

Select the appropriate channel on the satellite tuner. Then set the auxiliary mode as follows:

- If you own the A230E, A430E or A437E . . .
 . . . press **NUMBER** key "0" or **TV PROG.** on the remote control until "AU" appears on the recorder's front display panel.
- If you own the A233E, A237E or A433E . . .
 . . . press **NUMBER** key "0" or **TV PROG.** on the remote control until "AU2" appears on the recorder's front display panel.



6

INITIAL SETTINGS

Tuner Set

Your recorder needs to memorise all necessary stations in channel positions in order to record TV programmes. The Auto Tuning System automatically assigns all receivable stations in your area to call them up with the **TV PROG.** buttons without going through any vacant channels.

The following procedure describes how to select automatic channel setting.

1

TURN ON THE RECORDER

Press **OPERATE**.

2

ACCESS CH. SET DISPLAY

Press and hold **CH SET** for more than 2 seconds. "AUTO" appears on the front display panel.

- If you own the A237E or A437E . . . go directly to step 3.
- If you own the A230E, A233E, A430E or A433E . . . skip to step 5.

3

ACCESS COUNTRY DISPLAY

Press **OK** and the Country display appears on the front display panel.

4

SELECT COUNTRY

Press **PUSH JOG** $\Delta \nabla$ to select your country's name.



The available country names appear in the following order:

	"AUT" (Österreich)	"OTHR" (Others)
	"BELG" (Belgium)	"SWED" (Sverige)
$\Delta \downarrow$	"DEUT" (Deutschland)	"SUOM" (Suomi)
	"DK" (Danmark)	"SUIS" (Suisse)
$\nabla \uparrow$	"ESP" (España)	"PORT" (Portugal)
	"GRCE" (Greece)	"NOR" (Norsk)
	"ITA" (Italia)	"NL" (Nederland)

- If you own the A237E or A437E and you selected "BELG" or "SUIS" above . . . refer to "INFORMATION" at the end of this page.

5

START AUTO CHANNEL SET

Press **OK** and "AUTO" blinks on the front display panel.

- If you own the A237E or A437E and you selected "BELG" or "SUIS" in step 4 . . . refer to "INFORMATION" at the end of this page.

6

ACCESS CONFIRMATION DISPLAY

The channel position, channel and station name [A237E, A437E only] of the stations located by your recorder appear in a Confirmation display (☞ pg. 24).

(for HR-A237E, A437E)

Channel Position Channel Station Name



(for HR-A230E, A233E, A430E, A433E)



Ch=Regular CC=Cable

Confirm all the stored stations by using **PUSH JOG** $\Delta \nabla$.

- If you own the A230E, A233E, A430E or A433E . . . you can manually input the station name (☞ pg. 23).

7

RETURN TO NORMAL DISPLAY

Press **CH SET**.

- Using the Confirmation display, you can skip or add channel positions, enter station names and perform other operations. Refer to page 22 for the procedures.
- Depending on the reception conditions, the stations may not be stored in order, and (for A237E or A437E only) the station names may not be stored correctly.
- If you own the A233E or A433E and use a decoder, ☞ pg. 22 for information on scrambled broadcasts.

NOTES:

- Fine tuning is performed automatically when you select "AUTO" in step 2. If you want to perform it manually, refer to page 23.
- To set the tuner manually, refer to "Storing Channels Manually" (☞ pg. 22).

INFORMATION

If you own the A237E or the A437E and you selected "BELG" or "SUIS" in step 4, you need to enter the language used in your area. This ensures that stations broadcasting programmes in your language will be stored in the highest channel positions. Once you select a language, the recorder selects the region.

After pressing **OK** in step 5, perform the following procedure:

1. Press **PUSH JOG** $\Delta \nabla$ to select your language.
 - Users living in Belgium should select "DEUT", "FRA" or "NL".
 - Users living in Suisse should select "DEUT", "FRA" or "ITAL".

The available languages appear in the following order:

	"ENG" (English)	"DK" (Dansk)
$\Delta \downarrow$	"DEUT" (Deutsch)	"SUOM" (Suomi)
	"FRA" (Français)	"NOR" (Norsk)
$\nabla \uparrow$	"ITAL" (Italiano)	"SWED" (Svenska)
	"CAST" (Castellano)	"NL" (Nederlands)

2. Press **OK**, then go to step 6.

Clock Set

The following procedures are for the A230E, A233E, A430E and A433E.

1 TURN THE RECORDER ON

Press **OPERATE**.

2 ACCESS CLOCK SET DISPLAY

Press **CLOCK** on the remote control. The Clock Set display appears.



3 SET DATE AND TIME

Press **PUSH JOG** $\Delta\nabla$ to set the hour, then press **OK**. The "minutes" display begins blinking. Repeat the procedure to set the minutes, day, month and year.



4 START CLOCK OPERATION

Press **CLOCK**.

NOTES:

- During clock setting, if the day and month data are invalid (such as 31st April), the month digits are cleared automatically and the day digits begin blinking. Input the correct data.
- If, in step 3, the year digits are automatically cleared and the day digits begin blinking, it is possible that you have input 29th February for a non-leap year. Input the correct data.

The following procedures are for the A237E and the A437E.

If you performed Auto Channel Set (pg. 6), the recorder's built-in clock is also set automatically. The Auto and Manual clock setting procedures are necessary when . . .

- a power outage of more than 3 minutes occurs.
- the tuner has been set manually.
- the user desires to set the clock slightly ahead of the actual time.
- the clock was not set even after Auto Tuner Set was performed.

Whether you perform Auto or Manual clock setting, you can use the convenient Just Clock function.

Just Clock

The Just Clock function provides accurate time keeping through automatic adjustments at regular intervals, by reading data from a PDC signal.

The Just Clock option appears in the Just Clock display, and can be set "ON" or "OFF" (the default setting is "ON"). Press **OK** until the Just Clock setting begins blinking, then press **PUSH JOG** $\Delta\nabla$ to change the setting.

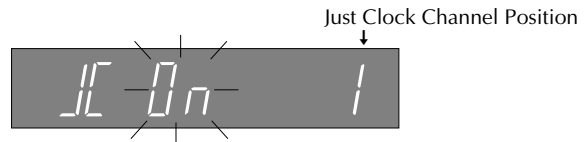

IMPORTANT: If you turn off Just Clock off, the accuracy of your recorder's built-in clock may be reduced, which could adversely effect timer recording.

Both Auto and Manual clock setting procedures begin from step 3.

Preparation

1 TURN THE RECORDER ON

Press **OPERATE**.

2 ACCESS CLOCK SET DISPLAY

Press **CLOCK** on the remote control. The Clock Set display appears.



CONTINUED ON NEXT PAGE.



8

INITIAL SETTINGS (cont.)

Auto Clock Set

SET CLOCK AUTOMATICALLY

3

At the Clock Set display, press **PUSH JOG ▷**. The Clock Set display blinks and clock setting begins.

- If the Just Clock channel position isn't set to the channel position on which Auto Clock data is received, "Err"(or) appears, and then the display from step 2 reappears. To set the Just Clock channel position, press **OK** until the Just Clock channel position begins blinking, then cycle through the numbers by pressing **PUSH JOG Δ ▽** until the number representing the channel position in which the station transmitting clock setting data is stored appears.

RETURN TO NORMAL DISPLAY

4

Once clock setting is completed, press **CLOCK** to return to the normal display.

Manual Clock Set

SET DATE AND TIME

3

Press **PUSH JOG Δ ▽** to set the hour, then press **OK**. The "minutes" display begins blinking. Repeat the procedure to set the minutes, day, month and year.



After inputting the year, press **OK** and the Just Clock display appears.

SET JUST CLOCK

4

The default setting is "ON". Set as desired by pressing **PUSH JOG Δ ▽**, then press **OK**.

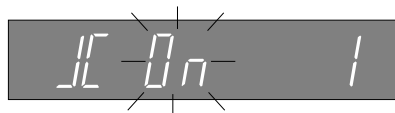

- If you set to "OFF", you can disregard the next step as you won't be able to receive regular clock adjustments.

SET CLOCK DATA SOURCE CHANNEL POSITION

5

The recorder is preset to receive clock setting and adjustment data from channel position 1. Press **PUSH JOG Δ ▽** to set the channel position to the number representing the station transmitting clock setting data, then press **OK**.

START CLOCK OPERATION

6

Press **CLOCK**.

NOTES:

- Auto Clock and Just Clock require a PDC signal, and will not operate with a VPS signal.
- Just Clock (when set to "ON") enables adjustment of the recorder's built-in clock every hour on the hour, except for 11 o'clock in the evening and midnight.
- Just Clock is not effective when . . .
 - the recorder's power is on (unless the recorder is tuned to the same channel position selected in the Just Clock display).
 - the recorder is in the Timer mode.
 - a difference of more than 3 minutes exists between the built-in clock's time and the actual time.
- If Just Clock is set to "ON", the recorder's clock is automatically adjusted at the start/end of Summer Time.
- Auto clock setting and Just Clock may not function properly depending on the reception condition.
- During Manual clock setting, if the day and month data are invalid (such as 31st April), the month digits are cleared automatically and the day digits begin blinking. Input the correct data.
- If, in step 3 of the Manual Clock Set procedure, the year digits are automatically cleared and the day digits begin blinking, it is possible that you have input 29th February for a non-leap year. Input the correct data.

Basic Playback

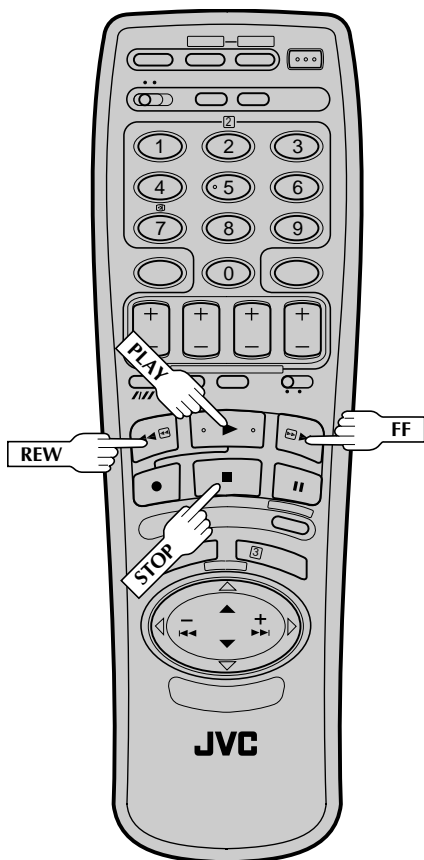
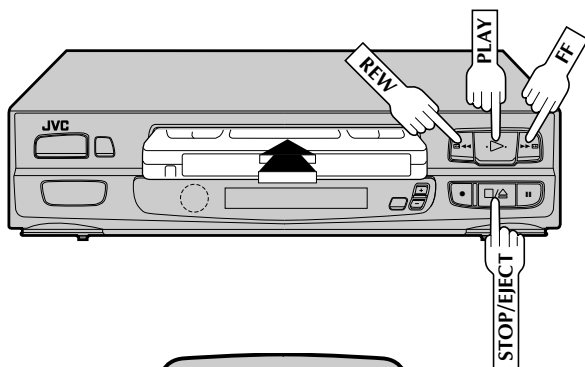

The easiest, most basic operation possible with your video recorder is tape playback. Already-recorded signals on a video tape are read by your video recorder and displayed on your TV just like a TV programme.

1 LOAD A CASSETTE

Make sure the window side is up, the rear label side is facing you and the arrow on the front of the cassette is point toward the recorder. Don't apply too much pressure when inserting.

- The recorder power comes on automatically and the counter is reset to 0:00:00.
- If the record safety tab has been removed, playback begins automatically.

2 FIND PROGRAMME START POINT

If the tape is advanced past the start point, press **REW**. To go forward, press **FF**.

3 START PLAYBACK

Press **PLAY**.

4 STOP PLAYBACK

Press **STOP** on the remote or **STOP/EJECT** on the recorder's front panel. Then press **STOP/EJECT** to remove the cassette.

Usable cassettes

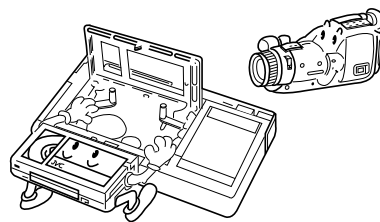

- Compact VHS camcorder recordings can be played on this video recorder. Simply place the recorded cassette into a VHS Cassette Adapter and it can be used just like any full-sized VHS cassette.
- This video recorder can record on regular VHS and Super VHS cassettes. However, it will record and play back regular VHS signals only. It is not possible to play back a recorded Super VHS tape.



Playback Features

Take advantage of special functions possible with the recorder's controls or the remote control.

Still Picture/Frame-By-Frame Playback

1 **PAUSE DURING PLAYBACK**
Press **PAUSE**. If there is vertical jitter, use the **TV PROG.** buttons to correct the picture.

2 **ACTIVATE FRAME-BY-FRAME PLAYBACK**

Press **PAUSE** again.

To resume normal playback, press **PLAY**.

Slow Motion

1 **ACTIVATE SLOW-MOTION PLAYBACK**

During still picture, press and hold **PAUSE** for 2 seconds, then release. Press and release again to return to still picture.

OR

During still picture, press and hold **PUSH JOG** ◀ or ▶. Release to return to still picture.

To resume normal playback, press **PLAY**.

Variable-Speed Search

1 **ACTIVATE VARIABLE-SPEED SEARCH**

During playback, press **PUSH JOG** ◀ or ▶.

- The more times you press, the faster the playback picture moves.
- To decrease speed, press the button for the opposite direction.

To resume normal playback, press **PLAY**.

High-Speed Search

1 **ACTIVATE HIGH-SPEED SEARCH**

During playback or still, press **FF** for forward high-speed search, or **REW** for reverse high-speed search.

- For short searches, during playback or still, press and hold **FF** or **REW** for over 2 seconds. When released, normal playback resumes.

To resume normal playback, press **PLAY**.



Manual Tracking

Your video recorder is equipped with automatic tracking control. During playback, you can override this and adjust the tracking manually by pressing the **TV PROG.** buttons.

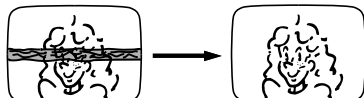

1 OVERRIDE AUTOMATIC TRACKING

Press **///** on the remote to engage manual tracking.

2 ADJUST TRACKING MANUALLY

Press **TV PROG. +** or **-** to adjust tracking.

3 RETURN TO AUTOMATIC TRACKING

Press **///** on the remote to re-engage automatic tracking.

NOTE:

When a new tape is inserted, the recorder enters the automatic tracking mode automatically.

Instant ReView

Simply by pressing a single button, the recorder power comes on, rewinds, and begins playback of the last timer-recorded programme. If you have several programmes recorded, you can easily access any of them.

NOTE:

Before starting, make sure that the recorder is off and that the Timer mode is disengaged.

1 ACTIVATE INSTANT REVIEW

Press **REVIEW**. The recorder power comes on and the recorder searches for the index code indicating the start of the last timer-recorded programme. Once it's found, playback begins automatically. The front display panel tells you how many programmes have been recorded. If you have, for example, 3 programmes, "REV 3" appears and blinks. To watch the first of the 3 programmes, press **REVIEW** three times. The recorder searches and begins playback automatically. You can access a programme as far as 9 index codes away from the current tape position.

NOTES:

- Instant ReView is not possible while the recorder is in the Timer mode.
- If you own the A237E or A437E, the number displayed to the right of "REV" may not match the actual number of timer-recorded programmes when one or more of them is a PDC/VPS recording (see pg. 19).

Repeat Playback

Your video recorder can automatically play back the whole tape 20 times repeatedly.

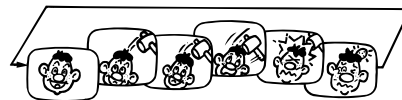

1 START PLAYBACK

Press **PLAY**.

2 ACTIVATE REPEAT PLAYBACK

Press **PLAY** and hold for over 5 seconds, then release.

- The Play indicator (▶) on the display panel blinks slowly.
- The tape plays 20 times automatically, and then stops.

3 STOP PLAYBACK

Press **STOP** at any time to stop playback.

NOTE:

Pressing **PLAY**, **REW**, **FF** or **PAUSE** also stops Repeat Playback.

NTSC Playback

Your video recorder is equipped with NTSC circuitry that can play back NTSC tapes.

1 LOAD A CASSETTE

Insert a cassette recorded in NTSC.

2 START PLAYBACK

Press **PLAY**. "NT" appears on the display panel.

- Some TVs shrink the picture vertically and place black bars at the top and bottom of the screen. This is not a malfunction on the part of either the video recorder or the TV.
- The picture may roll up and down. This can be corrected using the V-HOLD control found on some TVs. (This cannot be corrected if the TV does not have a V-HOLD control.)
- The counter and elapsed tape time readings will be incorrect.
- During search, still, or frame-by-frame playback, the picture will be distorted, and there may be a loss of colour.
- Depending on the type of TV, the top and bottom portions of superimposed displays may be cut off during NTSC playback.



Index Search

Your recorder automatically marks index codes at the beginning of each recording. This function gives you quick access to any one of 9 index codes in either direction.

NOTE:

Before starting, make sure the recorder is in the Stop mode.

1

ACTIVATE INDEX SEARCH

Press **PUSH JOG** ◀ or ▶ (◀◀ or ▶▶). “- 1” or “+ 1” is displayed on the display panel and search begins in the corresponding direction.

- To access index codes 2 through 9, press **PUSH JOG** ◀ or ▶ repeatedly until the correct index number is displayed.

Ex.: To locate the beginning of B from the current position, press **PUSH JOG** ◀ twice.
To locate the beginning of D from the current position, press **PUSH JOG** ▶ once.

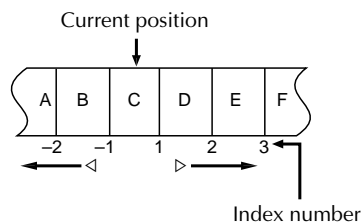

- When the specified index code is located, playback begins automatically.

Remote A/B Code Switching

The remote control is capable of controlling two JVC video recorders independently; one set to respond to the remote control's A code control signals and another set to respond to B code control signals. The remote control is preset to send A code signals because your video recorder is initially set to respond to A code signals. You can easily modify your video recorder to respond to B code signals.

1

REMOVE POWER SUPPLY

Unplug the mains power cord from the mains outlet.

2

SET A/B CODE SWITCH

Set to B.

3

RE-SUPPLY POWER

Plug the mains power cord back into the mains outlet.

4

TURN THE RECORDER ON

Press **OPERATE** on the remote control. The recorder will now only respond to B code signals.

NOTE:

Some TV sets may malfunction in response to the B mode. If this happens, switch back to the A mode.

Next Function Memory

You can set your recorder's power to go off automatically after the tape is fully rewound. Before starting, make sure the recorder is in the Stop mode.

For Automatic Power Off After Tape Rewind . . .
. . . press **REW**, then press **OPERATE** within 2 seconds.

Information On Colour System

You can also record SECAM signals, or play back a MESECAM tape on this recorder. When a MESECAM tape is played back, "MES" appears on the display panel. MESECAM is the designation for tapes with SECAM signals that have been recorded on a MESECAM-compatible PAL video recorder.

Basic Recording

TV signals being received by the recorder's built-in tuner can be recorded onto a video tape. You can "capture" a TV programme using your video recorder.

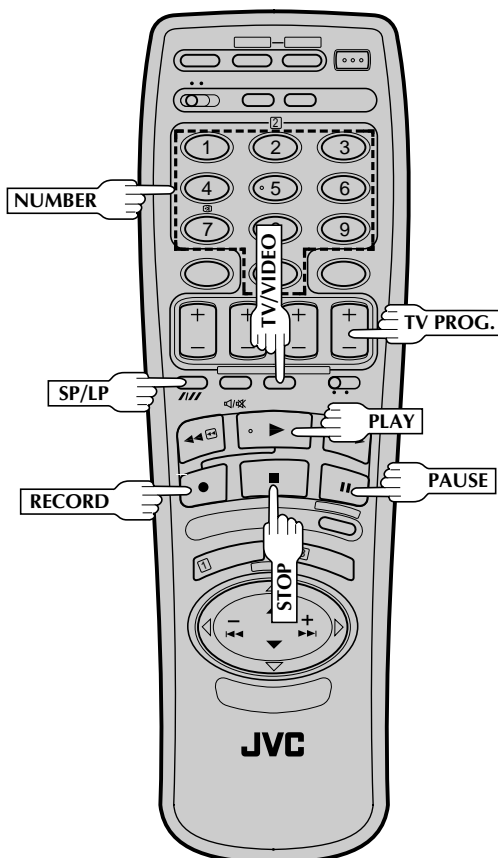
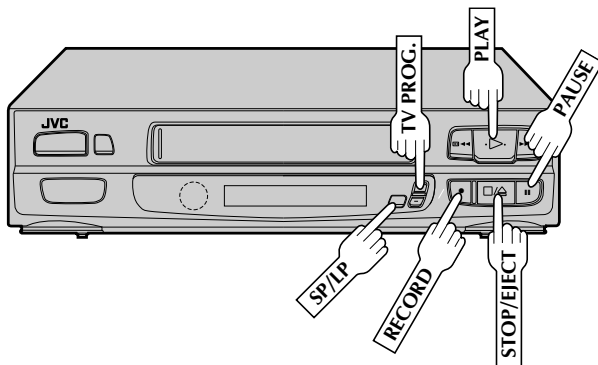

1 LOAD A CASSETTE

Insert a cassette with the record safety tab intact.

- The counter is reset to 0:00:00 and the recorder power comes on automatically.
- If your recorder is connected to the TV via AV connection, press **TV/VIDEO** to select the VIDEO mode. [A233E, A433E only]

2 CHOOSE A PROGRAMME

Press **TV PROG.** +/- or the **NUMBER** keys to select the channel you wish to record. The name of the station appears in the recorder's display panel for 5 seconds, followed by the channel position number. (Only stations that appear in the Confirmation display will be displayed.)

3 SET TAPE SPEED (A430E, A433E, A437E ONLY)

Press **SP/LP** (//). Check the SP/LP indicator on the recorder display panel to confirm the selected tape speed.

4 START RECORDING

Press and hold **RECORD** and **PLAY** on the remote control, or press **RECORD** on the recorder.

5 PAUSE/RESUME RECORDING

Press **PAUSE**. Press **PLAY** to resume recording.

6 STOP RECORDING

Press **STOP** on the remote control or **STOP/EJECT** on the recorder. Then press **STOP/EJECT** to remove the cassette.

Accidental erasure prevention

- To prevent accidental recording on a recorded cassette, remove its safety tab. To record on it later, cover the hole with adhesive tape.

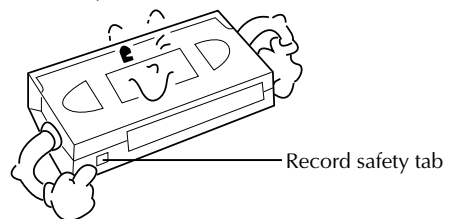

Recording Features

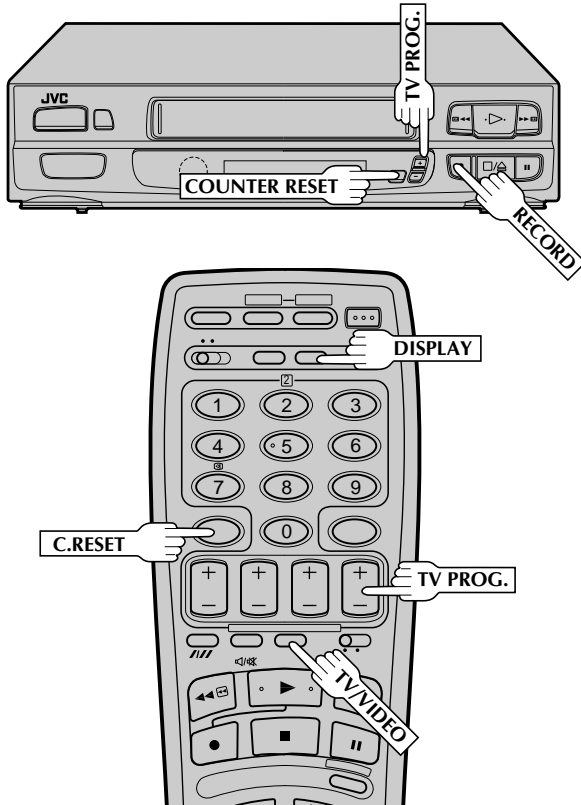

Record One Programme While Watching Another

If you own the A233E or the A433E and your recorder is connected to the TV via AV connection, . . .
 . . . press **TV/VIDEO**. The recorder's VIDEO indicator and the TV broadcast being recorded disappear.

1 SELECT CHANNEL TO WATCH

Once recording is in progress, all you need to do is to set the channel controls on the TV for the station you wish to view.

- The programme selected with the TV's channel controls appears on the TV screen while the one selected with the **TV PROG.** button is recorded on the tape.
- If you own the A233E or the A433E and a decoder is connected to the recorder (see pg. 4) . . .
 . . . you can select a scrambled channel as well with the TV channel controls.

Elapsed Recording Time Indication

You can check the exact time of a recording.

1 SET COUNTER DISPLAY

Press **DISPLAY** so that a counter reading appears on the display panel.

- If you press **DISPLAY** again, clock display appears.

2 RESET COUNTER

Press **C. RESET** before starting recording or playback.

- The counter is reset to "0:00:00" and shows the exact elapsed time as the tape runs.
- If you own the A230E, A233E or A237E, you can also use the recorder's **COUNTER RESET** button.

Instant Timer Recording (ITR)

This easy method lets you record for from 30 minutes to 6 hours (selectable in 30-min. increments), and shuts the recorder off after recording is finished.

1 START RECORDING

Press **RECORD** on the recorder.

2 ENGAGE ITR MODE

Press **RECORD** again. ITR blinks and 0:30 appears on the front display panel.

3 SET RECORDING DURATION

If you want to record for more than 30 minutes, press **RECORD** to extend the time. Each press extends recording time by 30 minutes.

NOTE:

You can only perform ITR using the **RECORD** button on the recorder's front panel.



Information On ShowView

The following procedures do not apply to the A230E and the A430E.

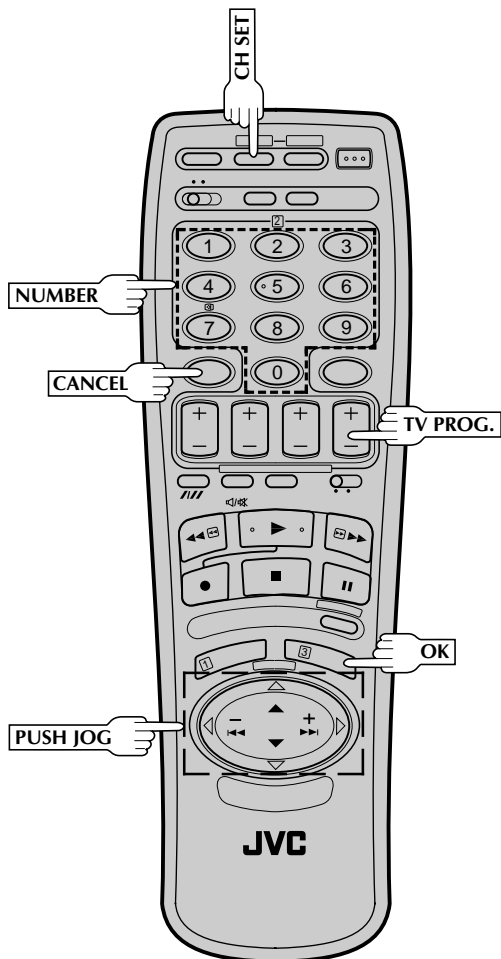
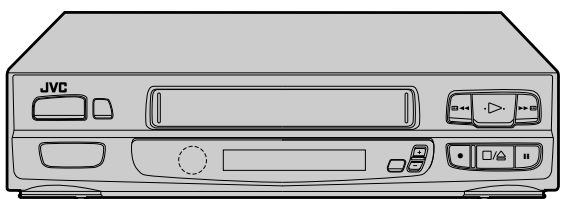

With ShowView, timer programming is greatly simplified because each TV programme has a corresponding code number which your recorder is able to recognise.

NOTE:

"Guide Prog. Number" refers to the assigned TV station numbers, according to broadcast area, for ShowView timer recording.

IMPORTANT

Perform the following procedure after the channel setting steps on pages 6 and 22 – 23, and after the Clock Set procedure on page 7.

After setting the Guide Prog. Numbers, the station names and channel positions may be incorrect if you stored or skipped channels. In this case, re-perform Guide Prog. Number setting.

Guide Prog. Number Set

1 MAKE LIST OF STORED CHANNEL POSITIONS AND STATION NAMES

(Ex.)	Channel position	Station name
	1	ARD
	2	ZDF
	3	WDR

2 ACCESS CH. SET DISPLAY

Press and hold **CH SET** for over 2 seconds. "AUTO" appears on the front display panel.

3 ACCESS GUIDE PROG. SET DISPLAY

Press **PUSH JOG** $\Delta \nabla$ to select "GUID", then press **OK**. The Guide Prog. Set display appears.

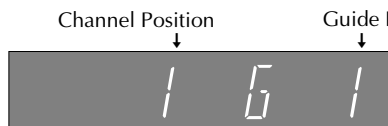

CONTINUED ON NEXT PAGE.



16

TIMER RECORDING(cont.)

4

ENTER SHOWVIEW NUMBER

Press **OK**, and "—" appears. Then, using the **NUMBER** keys, input the ShowView number (found in most TV listings) of a program scheduled to be broadcast on each station on the list from step 1, starting at the top. If you enter the wrong number, press **CANCEL** and input the correct number.



5

ENTER CHANNEL POSITION NUMBER

Press **OK** and Channel Position number begins blinking.

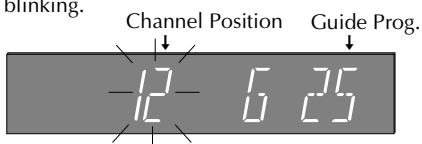

If the blinking Channel Position number agrees with the channel position . . .

. . . press **OK**.

If the numbers do not agree . . .

. . . input the channel position using **PUSH JOG**▲▼ or the **NUMBER** keys, then press **OK**.

- If you input the ShowView number of a program that has already aired, "Err"(or) appears on the front display for a few seconds. Input the correct ShowView number.
- Repeat steps 4 and 5 as necessary.

6

RETURN TO NORMAL DISPLAY

Press **CH SET** and selection is complete.

If you already know the Guide Prog. number for a station . . .

- 1- After step 3, press **PUSH JOG**▷.
 - The Guide Prog. number begins blinking.
- 2- Enter the Guide Prog. number using the **NUMBER** keys or **PUSH JOG**▲▼, then press **PUSH JOG**▷.
 - The Channel Position number begins blinking.
- 3- Enter the channel position using the **NUMBER** keys or **PUSH JOG**▲▼, then press **OK**.
 - Repeat 1 and 3 as necessary.
- 4- Press **CH SET**.

Satellite Tuner Users

To set the Guide Prog. numbers for satellite broadcasts, be sure to select the appropriate channel position in step 5 by using the **NUMBER** key "0" or **TV PROG.** +/-:

If you own the A437E...

... select "AU".

If you own the A233E, A237E or A433E...

... select "AU 2".



ShowView Timer Recording

ShowView Timer Recording is not available in models A230E and A430E. Before performing ShowView Timer Recording, see "Information on ShowView" on page 15.

Turn on the recorder first and perform the following steps.

1

ACCESS TIMER PROGRAMMING DISPLAY

Press **PROG.**



2

ENTER SHOWVIEW NUMBER

Press the **NUMBER** keys to enter the ShowView number of a programme you wish to record.



- If you make a mistake, press **CANCEL** and then input the correct number.

3

ACCESS PROGRAMME DISPLAY

Press **OK**, and the Programme display appears.



Press **PROG. CHECK** to confirm the date and the channel position.



- If the number you entered is invalid, "Err"(or) appears. Press **CANCEL** and input a valid ShowView number.
- The PDC/VPS indicator (Ⓜ) only appears with the A237E and the A437E. If you're not receiving PDC/VPS, press **NUMBER** key "7" to set Ⓜ to "OFF" so that the indicator disappears. (ⓘ pg. 19).

SET TAPE SPEED (A430E, A433E, A437E ONLY)

Press **SP/LP (///)** to set the tape speed.

4

RETURN TO NORMAL DISPLAY

Press **OK**.

5

- Repeat steps 1–5 for each additional programme.

6

ENGAGE RECORDER'S TIMER MODE

Press **TIMER**.

NOTE:

*For safety, your recorder disables all other functions while in the Timer mode. If you want to use the recorder but its Timer mode is engaged, press **TIMER** and all other functions are operable. To re-engage the timer, press **TIMER**.*

To Delay The Stop Time . . .

. . . press **ADD TIME (NUMBER** key "5") after pressing **OK** in step 3. Each time you press, the Stop time is delayed by 5 minutes (meaning that 5 minutes of recording time is added). You can easily compensate for anticipated programme schedule delays this way.

To Timer-Record Weekly Or Daily Serials . . .

. . . after pressing **OK** in step 3, press **WEEKLY (NUMBER** key "9") for weekly serials or **DAILY (NUMBER** key "8") for daily serials (Monday–Friday). "W" or "D" appears on the front display panel.

You can programme this recorder to timer-record as many as 8 programmes. If you try to programme the recorder to record a ninth, "FULL" appears on the front display panel. To record the extra programme, you must first cancel any unnecessary programmes (ⓘ pg. 19).

To Satellite Tuner Users

When timer-recording a satellite programme using ShowView, after performing steps 1 – 6, set the satellite tuner to the appropriate channel before the selected programme begins. Then set the satellite tuner's timer. If the tuner doesn't have a timer, leave the unit's power turned on.

Regular Timer Programming

Remember, the clock must be set before you can programme the timer (☞ pg. 7).

Turn on the recorder first and perform the following steps.

1 ACCESS TIMER PROGRAMMING DISPLAY

Press **PROG.**

- If you own the A230E or A430E ... skip to step 3.

2 ACCESS PROGRAMME DISPLAY

Press **START +/-**.



- The PDC/VPS indicator (☒) only appears with the A237E and the A437E. If you're not receiving PDC/VPS, press **NUMBER** key "7" to set to "OFF" so that the indicator disappears (☞ pg. 19).

3 ENTER PROGRAMME START TIME

Press **START +/-** to enter the time you want recording to start.

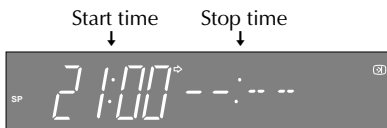

- Press and hold **START +/-** to move in 30-minute increments, or press and release repeatedly to move 1 minute at a time.

4 ENTER PROGRAMME STOP TIME

Press **STOP +/-** to enter the time you want recording to stop.

5 ENTER PROGRAMME DATE

Press **DATE +/-**. (The current date appears on the front display panel. The date you enter appears in its place.)

6 ENTER CHANNEL POSITION

Press **TV PROG. +/-**.

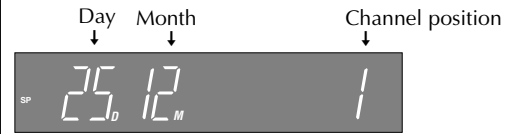

7 SET TAPE SPEED (A430E, A433E, A437E ONLY)

Press **SP/LP (//)** to set the tape speed.

8 RETURN TO NORMAL DISPLAY

After confirming all information is correct, press **OK** and the normal display appears.

- Repeat steps 1–8 for each additional programme.

9 ENGAGE RECORDER'S TIMER MODE

Press **TIMER**.

To Timer-Record Weekly Or Daily Serials . . .
 . . . anytime during steps 2 through 8, press **WEEKLY** (**NUMBER** key "9") for weekly serials or **DAILY** (**NUMBER** key "8") for daily serials (Monday–Friday). "W" or "D" appears on the front display panel.

NOTES:

- For safety, your recorder disables all other functions while in the Timer mode. If you want to use the recorder but its Timer mode is engaged, press **TIMER** and all other functions are operable. To re-engage the timer, press **TIMER**.
- You can programme this recorder to timer-record as many as 8 programmes. If you try to programme the recorder to record a ninth, "FULL" appears on the front display panel. To record the extra programme, you must first cancel any unnecessary programmes (☞ pg. 19).

To Satellite Tuner Users

When using the Regular Timer Recording method to timer-record a satellite programme, first set the auxiliary mode.

- If you own the A230E, A430E or A437E . . .
 . . . select "AU" in step 6.
- If you own the A233E, A237E or A433E . . .
 . . . select "AU2" in step 6.

Before the selected programme begins, set the satellite tuner for the appropriate channel, then set the tuner's timer. If your satellite tuner doesn't have a timer, leave its power on.



Check And Cancel Programmes

1

ACCESS PROGRAMME DISPLAY

Press **PROG CHECK**. The recording start and stop times appear on the front display panel. Then press **OK** and the date and the channel position appear. Each time you press **PROG CHECK** the next program's information appears.

If All Information Is Correct . . .

. . . programming is completed.

If You Wish To Revise Data . . .

. . . with the recorder's power turned on, go to step 2.

If You Wish To Cancel A Program . . .

. . . with the recorder's power turned on, press **CANCEL**. All information you input is deleted.

2

REVISE PROGRAMME INFORMATION

Input the appropriate data using the **START +/-**, **STOP +/-**, **DATE +/-** and **TV PROG. +/-** buttons on the remote control.

PDC/VPS Recording (A237E, A437E only)

Now available from some TV stations, PDC (Programme Delivery Control) and VPS (Video Programme System) are services designed to assure safe, accurate timer recording. With this system, special code signals are transmitted together with the audio/video signals. These code signals control your video recorder and have precedence over advertised times you preset in the timer. This means that your recorder will start and stop recording when the preset TV programmes actually start and end — even if the broadcast time of a preset TV programme is changed.

To Use PDC/VPS Service . . .

The default setting for PDC/VPS is "ON". To cancel PDC/VPS, press **NUMBER** key "7" so that the PDC/VPS indicator (Ⓜ) on the display panel disappears during ShowView or regular timer programming.

NOTES:

- When you manually enter programmes (regular timer programming), set the start time (PDC or VPS time) exactly as advertised in the TV listing. A different time than advertised will result in no recording.
- If you own the A237E, PDC/VPS recording is also possible when a satellite tuner or a cable system is connected to AV2 IN on your recorder.
- When PDC/VPS recording is performed, the Instant ReView programme readout number may not match the actual number of programmes that have been timer-recorded (Ⓜ pg. 11).



Edit To Or From Another Video Recorder

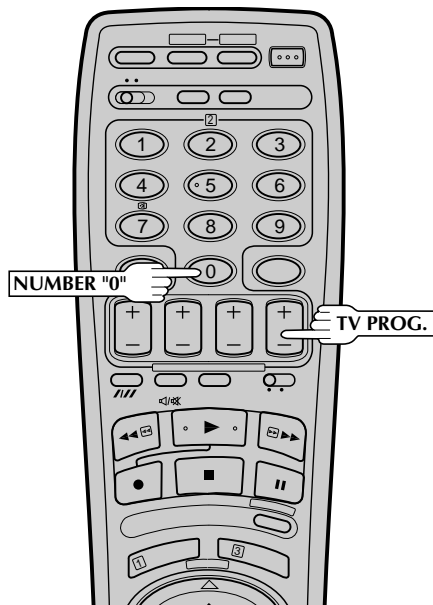

You can use your video recorder as the source player or the recording deck.

1 MAKE CONNECTIONS

Connect the player's AUDIO/VIDEO OUT connector to the recorder's AUDIO/VIDEO IN connector.

When Using Your Video Recorder As The Source Player . . .
. . . connect its AV1 IN/OUT connector to the recording deck.

When Using Your Video Recorder As The Recording Deck . . .
. . . you can use the AV1 IN/OUT or AV2 IN connectors. However, the AV2 IN connector is only available on the A233E, A237E and A433E.

2 SET RECORDING DECK'S INPUT MODE

Set to AUX. With this video recorder, press **NUMBER** key "0" and/or **TV PROG.** to select depending on the connector being used — "AU 1" or "AU" for the AV1 IN/OUT connector, or "AU 2" for the AV2 IN connector.

- (For A233E and A433E) When using the AV2 IN connector, make sure the **AV2 SELECT** switch is set to "AV2".

3 START SOURCE PLAYER

Engage its Play mode.

4 START RECORDING DECK

Engage its Record mode.

NOTE:

All necessary cables can be obtained from your dealer.

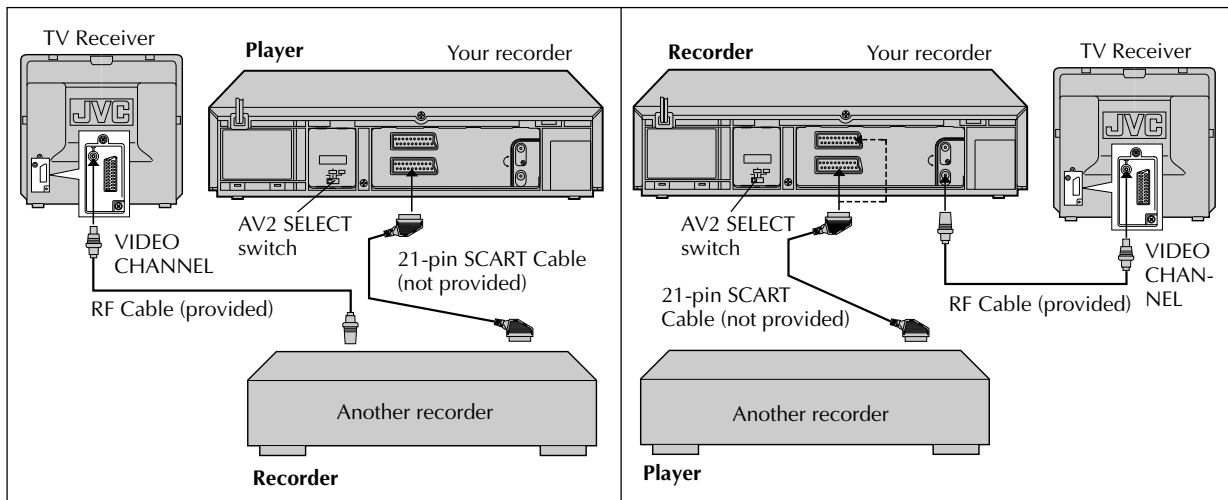

Edit From A Camcorder

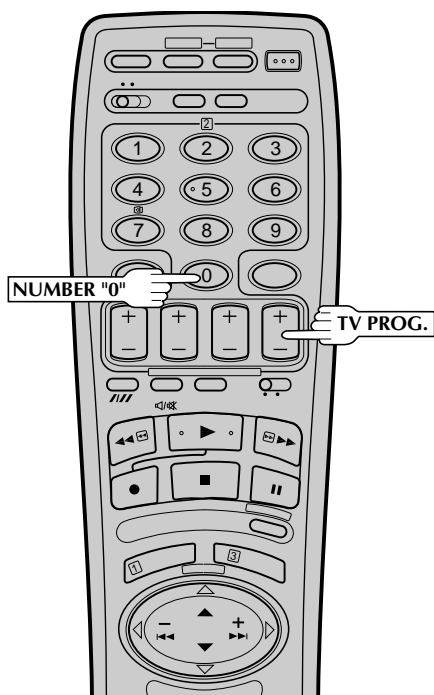

You can use a camcorder as the source player and your video recorder as the recorder.

1 MAKE CONNECTIONS

Connect the camcorder's AUDIO/VIDEO OUT connectors to the recorder's AUDIO/VIDEO input connectors.

2 SET RECORDER'S INPUT MODE

- If you're using the AV1 IN/OUT connector . . . select "AU" or "AU1" by pressing **NUMBER** key "0" and/or **TV PROG.**
- If you're using the AV2 IN connector . . . select "AU2" by pressing **NUMBER** key "0" or **TV PROG.**

If you own the A233E or A433E, make sure that the **AV2 SELECT** switch is set to "AV2".

3 START CAMCORDER

Engage its Play mode.

4 START RECORDER

Engage its Record mode.

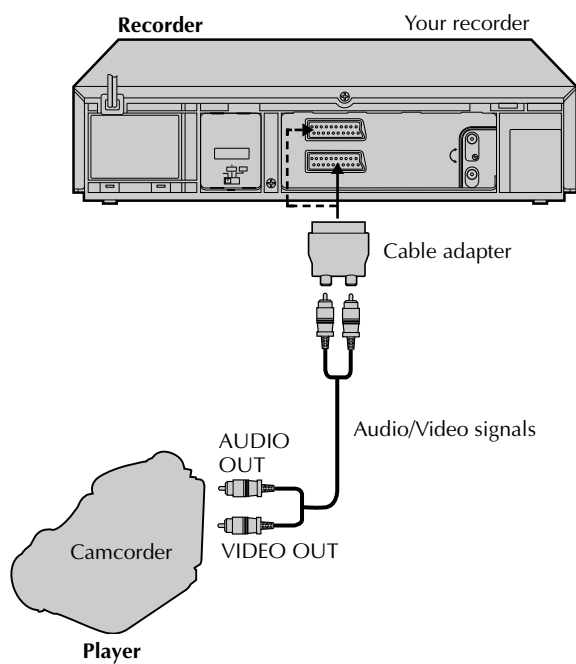



Storing Channels Manually

Store channels that were not stored during Auto Channel Set.

1

ACCESS CH. SET DISPLAY

Press and hold **CH SET** for more than 2 seconds. "AUTO" appears on the front display panel.

2

ACCESS CONFIRMATION DISPLAY

Press **PUSH JOG** $\Delta \nabla$ to select "MANU"(AL), then press **OK**. The Confirmation display appears.

3

SELECT POSITION

Press **PUSH JOG** $\Delta \nabla$ is until an open position in which you want to store a channel is displayed, then press **OK**. The Manual Ch. Set display appears.

Channel Position Channel Decoder setting



- Decoder setting appears only with A233E or A433E.

4

INPUT CHANNEL

The channel number "02" appears blinking. Press the **NUMBER** keys to input the channel number you want to store.

- Although the channel number is set to "02", when the Manual Ch. Set display appears, to store channel 02, you must select "02" using the **NUMBER** keys.
- For fine tuning adjustment, press **PUSH JOG** $\triangleleft \triangleright$ until the channel number blinks, then press **PUSH JOG** $\Delta \nabla$. While tuning, "—" or "—" appears.
- If necessary, to change the band between Ch(regular) and CC(cable), press **PUSH JOG** $\triangleleft \triangleright$ until Ch or CC is blinking, then press **PUSH JOG** $\Delta \nabla$ to select the band.
- (For A233E and A433E) When storing a channel that sends scrambled broadcasts, press **PUSH JOG** \triangleright until "OFF" (decoder setting) blinks, then press **PUSH JOG** $\Delta \nabla$ to set to "ON" ("OFF" is the default setting). Make sure that the **AV2 SELECT** switch is set to "DECODER" (pg. 4).

5

ENTER NEW CHANNEL INFORMATION

Press **OK** or **STORE**, and the Confirmation display appears.



- Repeat steps 3 through 5 as necessary.

6

RETURN TO NORMAL DISPLAY

Press **CH SET**.

- To input the station name, see page 23.
- To change positions, see "Change Station Channel Position".

To A233E/A433E Owners:

When Receiving A Scrambled Broadcast

Make sure that the **AV2 SELECT** switch is set to "DECODER" (pg. 4).

- 1- Perform steps 1 and 2 in the left column.
- 2- Press **PUSH JOG** $\Delta \nabla$ to select the position of the channel broadcasting the scrambled programmes, then press **OK** three times.
- 3- Press **PUSH JOG** $\triangleleft \triangleright$ until "OFF" (decoder setting) begins blinking, and set it to "ON" by pressing **PUSH JOG** $\Delta \nabla$.
- 4- Press **OK** to access the Confirmation display.
 - Repeat steps 2 – 4 for each additional channel.
- 5- Press **CH SET**.

Perform steps 1 and 2 of the previous procedure to access the Confirmation display before continuing.

Delete A Channel

1

SELECT STATION

Press **PUSH JOG** $\Delta \nabla$ until the station you want to delete is displayed.

2

DELETE STATION

Press **CANCEL**.

- The stations following the cancelled station all move up one position.
- Repeat steps 1 and 2 as necessary.

3

RETURN TO NORMAL DISPLAY

Press **CH SET**.

Change Station Channel Position

1

SELECT ITEM

Press **PUSH JOG** $\Delta \nabla$ until the item you want to move is displayed. Then press **OK** and the station name (or "—") and its channel number begin blinking.



2

SELECT NEW POSITION

Press **PUSH JOG**△▽ to move the station to the new channel position, then press **OK**.

Example: If you moved the station in position 3 to position 7, the stations originally in positions 4–7 each move up one position.

- Repeat steps 1 and 2 as necessary.

3

RETURN TO NORMAL DISPLAY

Press **CH SET**.

Perform steps 1 and 2 of "Storing Channels Manually" on page 22 to access the Confirmation display before continuing.

Set Stations (A)

1

SELECT ITEM

Press **PUSH JOG**△▽ until the item you want is displayed. Then press **OK** twice and the station's name (or "-") begins blinking.



2

SELECT NEW STATION

Press **PUSH JOG**△▽ until the new station's name you want to store begins blinking. Registered station names (pg. 24) appear as you press **PUSH JOG**△▽.

3

SWITCH STATIONS

Press **OK**.

- Repeat steps 1 through 3 as necessary.

4

RETURN TO NORMAL DISPLAY

Press **CH SET**.

Set Stations (B)**NOTE:**

First perform step 1 of the above procedure.

2

SELECT STATION NAME CHARACTER

Press **PUSH JOG**▷ and the first letter of the station name (or "-") begins blinking.

3

ENTER NEW CHARACTER

Press **PUSH JOG**△▽ to cycle through the characters (A–Z, 0–9, -, *, +, — (space)) and stop when the desired one is indicated, then press **PUSH JOG**▷ to enter. Enter the remaining characters the same way (maximum of 4).

After entering all characters, press **OK**.

- Repeat steps 1 through 3 as necessary.
- If you make a mistake, press **PUSH JOG**◀▷ until the incorrect character begins blinking. Then enter the correct character by pressing **PUSH JOG**△▽.

4

RETURN TO NORMAL DISPLAY

Press **CH SET**.

Fine-Tuning Channels Already Stored

1

SELECT CHANNEL TO FINE-TUNE

Press **PUSH JOG**△▽ until the channel you want to tune is displayed.

2

ACCESS MANUAL CH. SET DISPLAY

Press **OK** three times. The Manual Ch. Set display appears.



- "OFF" (decoder setting) appears only with A233E or A433E.

3

PERFORM TUNING

Press **PUSH JOG**△▽ until the picture is its clearest. Then press **OK**.

- The Confirmation display appears.
- Repeat steps 1 through 3 as necessary.

4

RETURN TO NORMAL DISPLAY

Press **CH SET**.



ID*	STATION NAME
1000	TV1000
3SAT	3SAT
ADLT	ADULT
ANT3	ANTENA3
ARD	ARD
ARTE	ARTE
BBC	BBC GROUP
BBC1	BBC1
BBC2	BBC2
BR3	BAYERN3
C+	CANAL PLUS
C1	PORTUGUSES
CAN5	CANALE5
CH4	CHANNEL4
CH5	CHANNEL5
CHLD	CHILD
CINE	CINEMA
CLUB	TELECLUB
CMT	CMT
CNN	CNN
CSUR	ANDALUCIA
DISC	DISCOVERY
DR	DR TV
DRS	DRS
DSF	DSF
ETB1	ETB1
ETB2	ETB2
EURO	EURONEWS
EUSP	EUROSPORTS
FEMM	FEMMAN
FILM	FILM
FNET	FILMNET
FR2	France2
FR3	France3
GALA	GALAVISION
HR3	HESEN3
INFO	INFO-KANAL
ITA1	ITALIA1
ITA7	ITALIA7
ITV	ITV
JSTV	JSTV
KA2	KA2
KAB1	KABEL1
KAN2	KANAL2
LOCA	LOCAL
M6	M6
MBC	MBR
MCM	MCM
MDR	MDR
MOVE	MOVIE
MTV	MTV
MTV3	MTV3
N3	NORD3
N-TV	N-TV
NBC	NBC SUPER
NDR	NDR
NED1	NED1
NED2	NED2
NED3	NED3
NEWS	
NRK	NRK
ODE	ODEON
ORF1	ORF1

ID*	STATION NAME
ORF2	ORF2
ORF3	ORF3
OWL3	OWL3
PREM	PREMIERE
PRO7	PRO7
RAI1	RAI1
RAI2	RAI2
RAI3	RAI3
RET4	RETE4
21	TELE21
RTBF	RTBF1 or 2
RTL	RTL
RTL2	RTL2
RTL4	RTL4
RTP	RTP
S4	SCHWEIZ4
SAT1	SAT1
SBS	SBS
SHOW	SHOW
SIC	SOCIEDADE
SKY	SKY CHANNEL
SKYN	SKY NEWS
SPRT	SPORT
SRTL	SUPER RTL
STAR	STAR-TV
SVT1	SVT1
SVT2	SVT2
SW3	SUEDWEST3
TCC	TCC
TELE	TELE
TEL5	TELE5
TF1	TF1
TM3	TM3
TMC	TELEMONTECARLO
TNT	TNT INT
TRT	TRT INT
TSI	TSI
TSR	TSR
TV1	BRTN TV1
TV2	BRTN TV2
TV3	TV3
TVE1	TVE1
TVE2	TVE2
TVG	TV GALICIA
TVI	TV INDEPENDENT
TVN	TV NORGE
VCR	VIDEO
VERO	VERONICA
VH-1	VH-1
VIVA	VIVA
VIV2	VIVA2
VMTV	VIDEO MUSIC
VOX	VOX
VT4	VT4
VTM	VTM
WDR1	West1
WDR3	West3
YLE1	YLE1
YLE2	YLE2
ZDF	ZDF
ZTV	ZTV

* The ID designator appears on your recorder's front display panel.



TROUBLESHOOTING

Before requesting service for a problem, use this chart and see if you can repair the trouble yourself. Small problems are often easily corrected, and this can save you the trouble of sending your video recorder off for repair.

POWER		
SYMPTOM	POSSIBLE CAUSE	CORRECTIVE ACTION
1. No power is applied to the recorder.	<ul style="list-style-type: none"> • The mains power cord is disconnected. 	Connect the mains power cord.
2. The clock is functioning properly, but the recorder cannot be powered.	<ul style="list-style-type: none"> • "⊖" is displayed on the display panel. 	Press the TIMER button to turn the "⊖" indicator off.
TAPE TRANSPORT		
SYMPTOM	POSSIBLE CAUSE	CORRECTIVE ACTION
1. The tape does not run during recording.	<ul style="list-style-type: none"> • "□□" is displayed on the display panel. 	Press PLAY to turn the "□□" indicator off.
2. The tape will not rewind or fast-forward.	<ul style="list-style-type: none"> • The tape is already fully rewound or fast-forwarded. 	Check the cassette.
PLAYBACK		
SYMPTOM	POSSIBLE CAUSE	CORRECTIVE ACTION
1. The playback picture does not appear while the tape is running.	<ul style="list-style-type: none"> • If you're using the RF OUT connection, the TV receiver's channel selector is set to the wrong video channel. • If you're using the AV connection, the TV receiver is not set to the AV mode. 	<p>If you are using the RF OUT connection, set the TV receiver to the RF converter channel (UHF 36). (☞ pg. 3)</p> <p>If you are using the AV connection, set the TV to its AV mode.</p>
2. Noise appears during visual search.	<ul style="list-style-type: none"> • This is normal. 	
3. Noise appears during normal playback.	<ul style="list-style-type: none"> • The automatic tracking mode is engaged. 	Try manual tracking. (☞ pg. 11)
4. Noise appears during slow-motion playback.	<ul style="list-style-type: none"> • The automatic tracking mode is engaged. 	Try manual tracking. (☞ pg. 11)
5. Noise appears during still playback.		Press PAUSE a few times to remove the noise bars from the screen.
6. The playback picture is blurred or interrupted while TV broadcasts are clear.	<ul style="list-style-type: none"> • The video heads may be dirty. 	Consult your JVC dealer.
RECORDING		
SYMPTOM	POSSIBLE CAUSE	CORRECTIVE ACTION
1. Recording cannot be started.	<ul style="list-style-type: none"> • There is no cassette loaded, or the cassette loaded has had its Record Safety tab removed. 	Insert a cassette, or using adhesive tape, reseal the slot where the tab was removed.
2. TV broadcasts cannot be recorded.	<ul style="list-style-type: none"> • "AU" has been selected as the input mode. 	Set to the desired channel.

CONTINUED ON NEXT PAGE.



3. Tape-to-tape editing is not possible.	<ul style="list-style-type: none"> • The source (another video recorder, camcorder) has not been properly connected. • All necessary power switches have not been turned on. • The input mode is not correct. 	<p>Confirm that the source is properly connected.</p> <p>Confirm that all units' power switches are turned on. Set the input mode to "AU".</p>
4. Camcorder recording is not possible.	<ul style="list-style-type: none"> • The camcorder has not been properly connected. • The input mode is not correct. 	<p>Confirm that the camcorder is properly connected. Set the input mode to "AU".</p>

TIMER RECORDING

SYMPTOM	POSSIBLE CAUSE	CORRECTIVE ACTION
1. Timer recording won't work.	<ul style="list-style-type: none"> • The clock and/or the timer have been set incorrectly. • The timer is not engaged. 	<p>Re-perform the clock and/or timer settings. Press TIMER and confirm that "⊖" is displayed on the display panel.</p>
2. "⊖" and "⊞" on the display panel won't stop blinking.	<ul style="list-style-type: none"> • The timer is engaged but there's no cassette loaded. 	<p>Load a cassette with the Record Safety tab intact, or cover the hole using adhesive tape.</p>
3. The cassette is automatically ejected, and "⊖" and "⊞" on the display panel won't stop blinking.	<ul style="list-style-type: none"> • The loaded cassette has had its Record Safety tab removed. 	<p>Remove the cassette and cover the hole with adhesive tape, or insert a cassette with the Record Safety tab intact.</p>
4. "⊖" blinks for 10 seconds and the Timer mode is disengaged.	<ul style="list-style-type: none"> • TIMER has been pressed when there are no programs in memory, or the timer record information has been programmed incorrectly. 	<p>Check the programmed data and re-program as necessary, then press TIMER again.</p>
5. The cassette is automatically ejected, the power shuts off and "⊖" and "⊞" won't stop blinking.	<ul style="list-style-type: none"> • The end of the tape was reached during timer recording. 	<p>The programme may not have been recorded in its entirety. Next time make sure you have enough time on the tape to record the entire programme.</p>
6. ShowView does not timer-record properly.	<ul style="list-style-type: none"> • The recorder's channel positions have been set incorrectly. 	<p>Refer to "Guide Prog. Number Set" and re-perform the procedure (☞ pg. 15).</p>

OTHER PROBLEMS

SYMPTOM	POSSIBLE CAUSE	CORRECTIVE ACTION
1. Whistling or howling is heard from the TV during camcorder recording.	<ul style="list-style-type: none"> • The camcorder's microphone is too close to the TV. • The TV's volume is too high. 	<p>Position the camcorder so its microphone is away from the TV. Turn the TV's volume down.</p>
2. When scanning channels, some of them are skipped over.	<ul style="list-style-type: none"> • Those channels have been designated to be skipped. 	<p>If you need the skipped channels, restore them (☞ pg. 22).</p>
3. The channel cannot be changed.	<ul style="list-style-type: none"> • Recording is in progress. 	<p>Press PAUSE to pause the recording, change channels, then press PLAY to resume recording.</p>
4. The remote control won't operate a JVC TV.	<ul style="list-style-type: none"> • The TV/VCR switch is in the wrong position. 	<p>Set the switch to TV.</p>
5. Channel settings that were made manually seem to have changed or disappeared.	<ul style="list-style-type: none"> • After the manual settings were made, Auto Channel Set was performed. 	<p>Perform manual setting again.</p>



QUESTIONS AND ANSWERS

PLAYBACK

- Q. What happens if the end of the tape is reached during playback or search?**
A. The tape is automatically rewound to the beginning.
.....
- Q. Can the video recorder indefinitely remain in the still mode?**
A. No. It stops automatically after 5 minutes to protect the heads.
.....
- Q. During search, slow, still and frame-by-frame playback, I can't hear any audio. What's the problem?**
A. This is normal.
.....
- Q. When returning from multi-speed search to normal playback, the picture is disturbed. Should I be concerned about this?**
A. No, it is normal.
.....
- Q. Noise bars appear during multi-speed search. What's the problem?**
A. This is normal.
.....
- Q. Other than preventing further recording, what effect does removing the Record Safety tab have?**
A. It disables marking of index codes.
.....
- Q. Sometimes, during Index Search, the video recorder can't find the programme I want to see. Why not?**
A. There may be index codes too close together.
.....

RECORDING

- Q. When I pause and then resume a recording, the end of the recording before the pause is overlapped by the beginning of the continuation of recording. Why does this happen?**
A. This is normal. It reduces distortion at the pause and resume points.
.....
- Q. Can the video recorder indefinitely remain in the Record-Pause mode?**
A. No. The video recorder goes to its Stop mode automatically after 5 minutes to protect the heads.
.....
- Q. What happens if the tape runs out during recording?**
A. The video recorder automatically rewinds it to the beginning.
.....

TIMER RECORDING

- Q. "⊙" and "⊖" remain lit on the display panel. Is there a problem?**
A. No. This is a normal condition for a timer recording in progress.
.....
- Q. Can I program the timer while I'm watching a tape or a TV broadcast?**
A. Yes.
.....

ATTENTION:

This recorder contains microcomputers. External electronic noise or interference could cause malfunctioning. In such cases, switch the recorder off and unplug the mains power cord. Then plug it in again and turn the recorder on. Take out the cassette. After checking the cassette, operate the unit as usual.



List Of Terms

This guide serves as a quick way to locate frequently used terms. The first page on which the term appears is listed. Most terms appear more than once in the instruction manual.

A

- A/B Code Switch pg. 12
- A-Code Signals pg. 12
- Aerial pg. 3
- Auto Channel Set pg. 6
- Auto Clock Set pg. 8
- AUX pg. 20
- AV pg. 3
- AV Connection pg. 3

B

- B-Code Signals pg. 12

C

- Cancel pg. 19
- Cassette Adapter pg. 9
- Channel Position pg. 6
- Clock pg. 7
- Clock Set pg. 7
- Contents pg. 1
- Counter Reset pg. 14
- Country pg. 6

D

- Daily pg. 18
- Delete A Channel pg. 22
- Display Panel pg. 6

E

- Editing pg. 20

F

- Fine Tuning pg. 23
- Frame-By-Frame Playback pg. 10
- Front View pg. 29

G

- Guide Prog. Number pg. 15

H

- Head Cleaning pg. 2
- High-Seed Search pg. 10

I

- Index Code pg. 12
- Index Search pg. 12
- Instant ReView pg. 11
- Instant Timer Recording (ITR) pg. 14

J

- Just Clock pg. 7

L

- Load A Cassette pg. 9

M

- Manual Channel Set pg. 22
- Manual Clock Set pg. 8
- Manual Tracking pg. 11
- Moisture Condensation pg. 2

N

- Next-Function Memory pg. 12
- NTSC Playback pg. 11

P

- Programme Delivery Control (PDC) pg. 19
- Playback pg. 9

R

- Rear View pg. 29
- Record Safety Tab pg. 13
- Recording pg. 13
- Repeat Playback pg. 11
- RF Connection pg. 3

S

- Scart Connector pg. 3
- ShowView pg. 15
- Slow Motion pg. 10
- Specifications pg. 32
- Still Picture pg. 10

T

- Tape Speed pg. 13
- Timer Programming pg. 18
- Timer Recording pg. 15
- Tracking pg. 11
- Tuner pg. 6

V

- Variable-Speed Search pg. 10
- Video Programme System (VPS) pg. 19

W

- Weekly pg. 18

FRONT VIEW

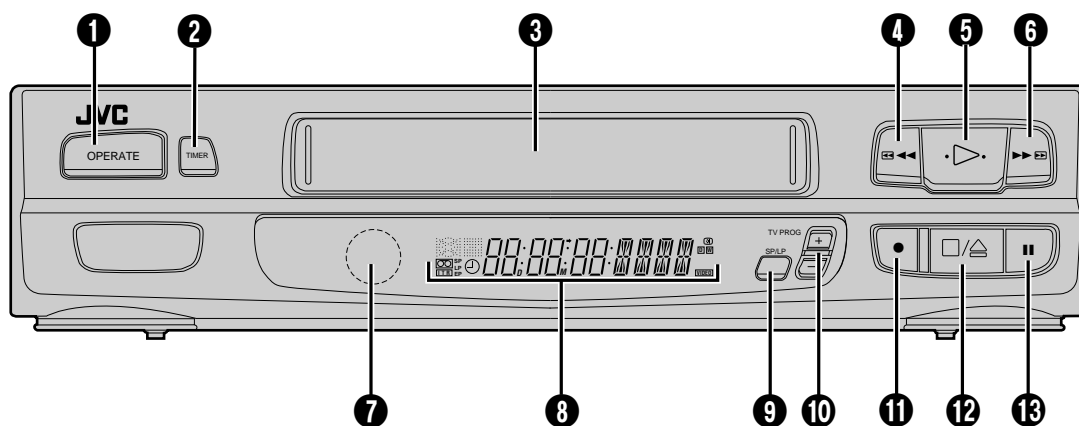

- ❶ OPERATE Button (☞ pg. 3)
- ❷ TIMER Button (☞ pg. 18)
- ❸ Cassette Loading Slot
- ❹ REWIND Button (☞ pg. 9)
- ❺ PLAY Button (☞ pg. 9)
- ❻ FAST-FORWARD Button (☞ pg. 9)
- ❼ Infrared Beam Receiving Window
- ❽ Display Panel (☞ pg. 31)
- ❾ SP/LP Button (☞ pg. 13) [A430E, A433E, A437E]
COUNTER RESET Button (☞ pg. 14)
[A230E, A233E, A237E]
- ❿ TV PROG. +/- Button (☞ pg. 6)
- ⓫ RECORD Button (☞ pg. 13)
- ⓬ STOP/EJECT Button (☞ pg. 9)
- ⓭ PAUSE Button (☞ pg. 10)

REAR VIEW

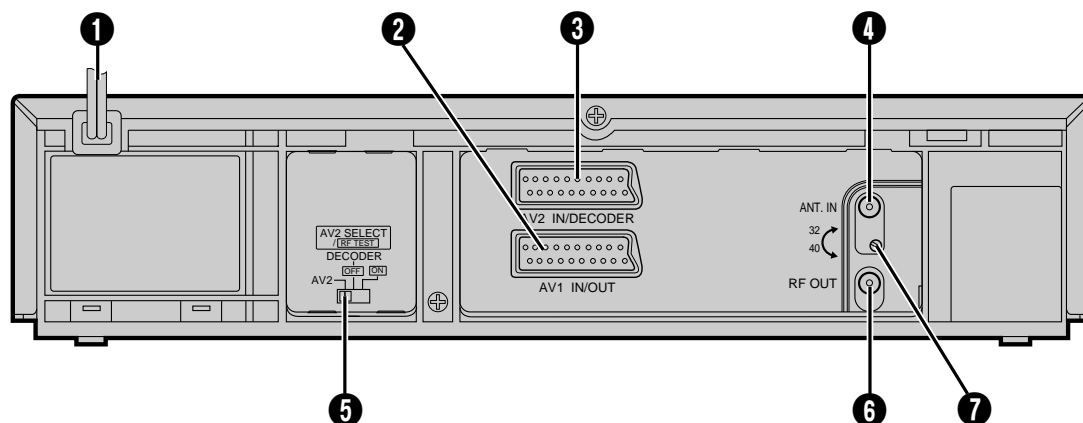

- ❶ Mains Power Cord (☞ pg. 3)
- ❷ AV1 IN/OUT Connector (☞ pg. 3)
- ❸ AV2 IN Connector (☞ pg. 5) [A237E]
AV2 IN/DECODER Connector (☞ pg. 4)
[A233E, A433E]
- ❹ ANT. IN Connector (☞ pg. 3)
- ❺ RF TEST switch (☞ pg. 3)
[A230E, A237E, A430E, A437E]
AV2 SELECT/RF TEST switch (☞ pg. 3)
[A233E, A433E]
- ❻ RF OUT Connector (☞ pg. 3)
- ❼ RF Output Channel Adjustment Screw (☞ pg. 4)

REMOTE CONTROL

Buttons shown in white (□) can also be used to operate JVC TVs.

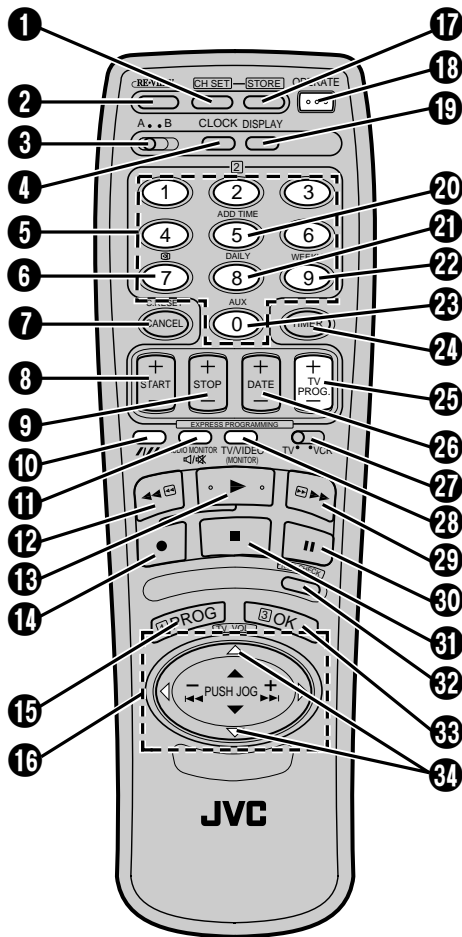

- 1 CH SET Button (☞ pg. 6)
- 2 REVIEW Button (☞ pg. 11)
- 3 A/B CODE Switch (☞ pg. 12)
- 4 CLOCK Button (☞ pg. 7)

- 5 NUMBER Keys (☞ pg. 13)
- 6 (PDC/VPS) Button (☞ pg. 19)
[A237E, A437E only]
- 7 CANCEL Button (☞ pg. 19)
- 8 C.RESET Button (☞ pg. 14)
- 8 START +/- Button (☞ pg. 18)
- 9 STOP +/- Button (☞ pg. 18)
- 10 /// (TRACKING) Button (☞ pg. 11)
- SP/LP Button (☞ pg. 13) [A430E, A433E, A437E only]
- DIGIT ENTRY Button (See below.)
- 11 TV MUTE Button (See below.)
- 12 Rewind [REW] Button (☞ pg. 9)
- 13 PLAY Button (☞ pg. 9)
- 14 RECORD Button (☞ pg. 13)
- 15 PROG Button (☞ pg. 18)
- 16 PUSH JOG Δ / ∇ Button (☞ pg. 6)
- PUSH JOG \triangleleft / \triangleright Button (☞ pg. 10)
- 17 STORE Button (☞ pg. 22)
- 18 OPERATE Button (☞ pg. 3)
- 19 DISPLAY Button (☞ pg. 14)
- 20 ADD TIME Button (☞ pg. 17)
- 21 DAILY Button (☞ pg. 18)
- 22 WEEKLY Button (☞ pg. 18)
- 23 AUX Button (☞ pg. 20)
- 24 TIMER Button (☞ pg. 18)
- 25 TV PROG. +/- Button (☞ pg. 6)
- 26 DATE +/- Button (☞ pg. 18)
- 27 TV/VCR Switch (See below.)
- 28 TV/VIDEO Button (☞ pg. 13)
- 29 Fast Forward [FF] Button (☞ pg. 9)
- 30 PAUSE Button (☞ pg. 10)
- 31 STOP Button (☞ pg. 9)
- 32 PROG CHECK Button (☞ pg. 19)
- 33 OK Button (☞ pg. 6)
- 34 TV VOL Δ / ∇ Button (See below.)

Installing Batteries

- 1 Open the battery compartment cover.
- 2 Insert 2 "R6"-size batteries (provided) in the correct directions.
- 3 Replace the cover.

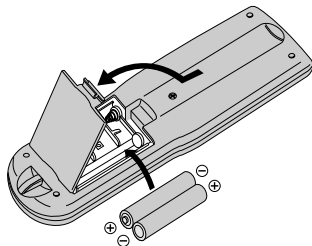

NOTE:

If for some reason the remote control doesn't work properly, remove its batteries, wait a short time and then try again.

How To Use

The remote control can operate most of your video recorder's functions, as well as basic functions of JVC TV sets (see below).

- Point the remote control toward the sensor window.
- The maximum operating distance of the remote control is about 8 m.

Operating JVC TVs

To operate your TV, set the TV/VCR switch to "TV". The OPERATE button, TV/VIDEO button, TV PROG. +/- buttons, TV VOL Δ / ∇ buttons and the MUTE button on the remote control can all be used to operate the TV. Use the NUMBER keys, and the DIGIT ENTRY (///) button or the PUSH JOG \triangleleft / \triangleright button to select the TV's channel. The DIGIT ENTRY (///) button corresponds to the 1-digit/2-digit entry switching button (often labelled -/-) on your TV's remote control. The PUSH JOG \triangleleft button corresponds to the 10+ button, and the PUSH JOG \triangleright button corresponds to the 20+ button of your TV's remote control.

NOTE:

The way these buttons are used is determined by your TV. Use these buttons as instructed for your TV's remote control.



DISPLAY PANEL

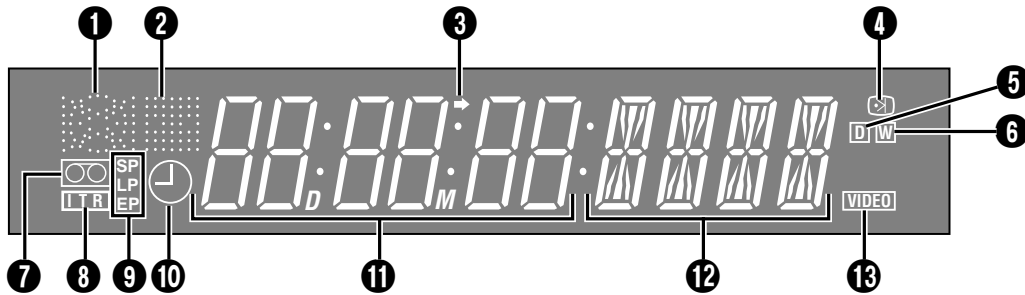

1 and 2 Symbolic Mode Indicators

PLAY:		REVERSE PLAY:	
FF:		STILL: FORWARD SLOW:	
REW:		STILL: REVERSE SLOW:	
FF VARIABLE SHUTTLE SEARCH:		RECORD:	
REW VARIABLE SHUTTLE SEARCH:		RECORD PAUSE:	

- 3 Start Time/Stop Time Indicator (pg. 18)
- 4 PDC/VPS Indicator (pg. 17)
[A237E, A437E only]
- 5 "DAILY" Program Mark (pg. 18)
- 6 "WEEKLY" Program Mark (pg. 18)
- 7 "Cassette Loaded" Mark
- 8 Instant Timer Recording (pg. 14)
- 9 Tape Speed Indicators (pg. 13) [A430E, A433E, A437E only]
- 10 "Timer" Indicator (pg. 18)
- 11 Clock/Counter Display (pg. 7)
- 12 Channel/Mode Display (pg. 6)
- 13 VIDEO indicator (pg. 10)
[A233E, A433E only]

GENERAL

Power requirement	: AC 220 – 240 V, 50/60 Hz
Power consumption	: 20 W
Temperature	
Operating	: 5°C to 40°C
Storage	: –20°C to 60°C
Operating position	: Horizontal only
Dimensions (WxHxD)	: 400 x 94 x 338 mm
Weight	: 4.3 kg
Format	: VHS PAL standard
Maximum recording time	
(SP)	: 240 min. with E-240 video cassette
(LP) [A430E, A433E, A437E only]	: 480 min. with E-240 video cassette

VIDEO/AUDIO

Signal system	: PAL-type colour signal and CCIR monochrome signal, 625 lines/50 fields
Recording system	: DA4 (Double Azimuth) head helical scan system (A430E, A433E, A437E) Rotary two-head helical scan system (A230E, A233E, A237E)
Signal-to-noise ratio	: 45 dB
Horizontal resolution	: 250 lines
Frequency range	: 70 Hz to 10,000 Hz
Input/Output	: [A230E, A430E, A437E] 21-pin SCART connector x 1 (IN/OUT x 1) [A237E] 21-pin SCART connector x 2 (IN/OUT x 1, IN x 1) [A233E, A433E] 21-pin SCART connector x 2 (IN/OUT x 1, IN/DECODER x1)

TUNER/TIMER

TV channel storage capacity	: 99 positions (+AUX position "AU")
Tuning system	: Frequency synthesized tuner
Channel coverage	: VHF 47 – 89/104 – 300/ 302 – 470MHz UHF 470 – 862MHz
Aerial output	: UHF channel 36 (Adjustable 32 – 40)
Memory backup time	: Approx. 3 min.

ACCESSORIES

Provided accessories	: RF cable, Infrared remote control unit, "R6" battery x 2
----------------------	--

*Specifications shown are for SP mode unless otherwise specified.
E. & O.E. Design and specifications subject to change without notice.*



JVC
VICTOR COMPANY OF JAPAN, LIMITED

